

Voltech

AC

Interface

User Manual



www.voltech.com



<http://www.voltech.com>

AC INTERFACE USER MANUAL

Voltech Instruments Inc.

2725 E. Millbrook Road, Suite 121

Raleigh, NC 27604

U.S.A.

Tel: +1 919 431 0015

Fax: +1 919 431 0090

sales@voltech.com

Voltech Instruments Ltd.

65 Milton Park, Abingdon

Oxfordshire

OX14 4RX, U.K.

Tel: +44 1235 834555

Fax: +44 1235 835016

sales@voltech.co.uk

Voltech Instruments is committed to a policy of continuous product development. Hence product specification and the information given in this manual are subject to change without notice.

No part of this publication may be reproduced, stored in a retrieval system, or transmitted in any form, or by means electronic, mechanical photocopying, recording or otherwise, without prior written permission of Voltech Instruments.

© 2001 Voltech Instruments. All rights reserved.

Microsoft, Windows and the Windows logo are either registered trademarks or trademarks of Microsoft Corporation in the United States and/or other countries.

Voltech Part Number: 98-072, Issue 1.0; September 2001



DANGER OF ELECTRIC SHOCK

Only qualified personnel should install this equipment, after reading and understanding this user manual. If in doubt, consult your supplier.



RISQUE D'ELECTROCUTION

L'installation de cet équipement ne doit être confiée qu'à un personnel qualifié ayant lu et compris le présent manuel d'utilisation. Dans le doute, s'adresser au fournisseur.



GEFAHR VON ELEKTRISCHEM SCHOCK

Nur entsprechend ausgebildetes Personal ist berechtigt, diese Ausrüstung nach dem Lesen und Verständnis dieses Anwendungshandbuches zu installieren. Falls Sie Zweifel haben sollten, wenden Sie sich bitte an Ihren Lieferanten.



RISCHIO DI SCARICHE ELETTRICHE

Solo personale qualificato può installare questo strumento, dopo la lettura e la comprensione di questo manuale. Se esistono dubbi consultate il vostro rivenditore.

IMPORTANT: Please consult the safety information section of this user manual before installation and use.

Contents

1. Introduction.....	1-1
1.1. Features & Abilities	1-1
1.2. Package Contents.....	1-3
1.3. Choosing an AC Source.....	1-5
1.4. Operating Description.....	1-8
2. Installation.....	2-1
2.1. General	2-1
2.2. Power Amplifier or Source with On / Off Control	2-1
2.3. AT Output Transformer	2-3
2.4. Line Supply or Manual Source	2-5
2.5. Constructing the Test Fixture	2-7
2.6. Testing the Complete System	2-8
3. Using the PC Editor	3-1
3.1. Configuration of External AC Source	3-1
3.2. Selection of Sense Method	3-4
3.3. Selection of External AC Source in AT Editor	3-4
4. Technical Information.....	4-1
4.1. Recommended Spares & Accessories.....	4-1
4.2. Details of Connector Functions	4-2
4.3. Using a Current Transformer.....	4-8
4.4. How to Choose a Shunt	4-10
4.5. Choosing an AT Output Transformer	4-12

5. Specification.....	5-1
5.1. Tests Available for Use with the AC Interface	5-1
5.2. MAGX – Magnetising Current.....	5-2
5.3. VOCX – Open Circuit Voltage	5-3
5.4. STRX & WATX – Stress Wattage & Wattage	5-4
5.5. Typical External AC Source Specification	5-6
5.6. General.....	5-7
5.7. EMC Compliance.....	5-8
5.8. EMC Precautions.....	5-9
6. Warranty & Service	6-1
6.1. Warranty.....	6-1
6.2. Service	6-2
6.3. Obtaining Service and Applications Support	6-2
7. Safety Information.....	7-1
7.1. Safety Features	7-1
7.2. Safety Instructions.....	7-1
7.3. Error Messages	7-2
7.4. Compliance with EN954	7-4

1. INTRODUCTION

Thank you for choosing to use this Voltech product. If you experience any difficulty during installation or use of the Voltech AC Interface, or are unsure of any of its features or abilities, please do not hesitate to contact either your local Voltech supplier or one of our Voltech main service centres.

1.1. FEATURES & ABILITIES

The Voltech AC Interface is a versatile, easy-to-use accessory for the Voltech AT3600 transformer tester. The AC Interface:

- Extends the range of wound components that may be tested by the AT3600 by allowing a variety of third-party AC sources to provide the test signal.
- Can be used with external sources that provide up to 600V @ 10A, 20Hz to 1MHz for testing higher power transformers.
- Automatically controls the AC source to optimise test speed and enhance operator safety.
- Integrates the AC source seamlessly into the AT3600 environment and allows all other standard tests to be executed in the same program that is used by the external source.
- Fits into the rear part of the fixture bay on an AT3600.
- Provides a convenient method of connection between the source, the AT3600 and the test piece.
- Comes with all necessary inter-connecting leads supplied.
- Isolates the AT3600 from the external source, when the external source is not being used, preventing damage to the source during high-voltage testing.

- Allows a step-up or step-down transformer to be used to boost the voltage or current of the AT3600's internal generator.

- Makes four tests available for use with the AT3600 and an AC source:
 - MAGX - Magnetising Current (External Source)
 - VOCX - Open Circuit Voltage (External Source)
 - WATX - Wattage (External Source)
 - STRW - Stress Wattage (External Source)

1.2. PACKAGE CONTENTS

The following items are supplied with your AC interface. Please check that you have every item and report any missing items to your Voltech supplier as soon as possible. Returning your product registration card will ensure that you continue to receive the latest product and application information.

- Voltech AC Interface Fixture

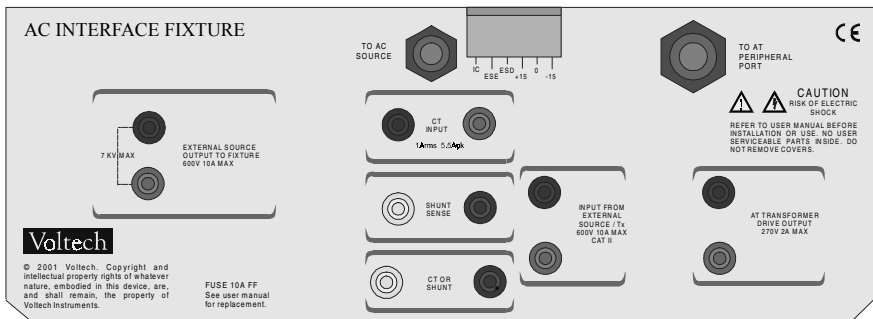

- Voltech AC Interface user manual
- Kelvin clip leads, 10A rated (Voltech part no.: 78-060)
 - For use during program design, or when the transformer does not have PCB connections.
- One black (Voltech part no.: 78-067) and one red (Voltech part no.: 78-068) 4mm safety to 4mm stackable AC test leads
 - For connecting the 'External Source Output' connectors of the Interface to the test fixture.
- Two pairs of red (Voltech part no.: 78-057) and black (Voltech part no.: 78-058) 4mm safety to bare tinned leads.
 - One pair for connecting the external source or transformer secondary to the 'Input from External Source' connector of the AC Interface.

The other pair for connecting the 'AT Transformer Drive Output' to the primary of a transformer (if used).

- One yellow 4mm and one blue 4mm safety socket.

For fitting to the test fixture to accept the leads from the 'External Source Output' of the AC Interface.

- One current transformer (CT 10-20)

A precision current transformer that fits directly onto the AC Interface.

- Certificate of Conformance
- Voltech product registration card

1.3. CHOOSING AN AC SOURCE

To provide system reliability, integration with existing tests and operator safety, the Voltech AC Interface must be able to control the output of the external AC source that is being used with it. The AC Interface allows four different types of AC sources to be used for testing:

- A power amplifier
- An AC source with remote logic on / off control
- A voltage or current step-up transformer
- An un-controlled AC source

A **power amplifier** is an AC source that can be configured so that its AC voltage output is a fixed multiple of a small AC voltage control input. The output frequency of a power amplifier is the same as the input frequency of the small AC voltage control.

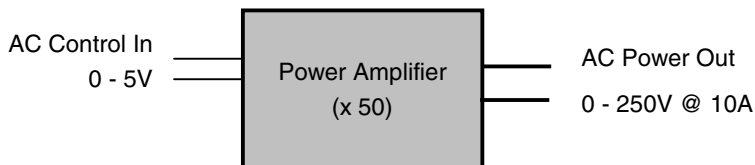

A power amplifier is Voltech's preferred choice of an external AC source to be used with the AT3600 transformer tester and the AC Interface. Using a power amplifier, the AT3600 will:

- Control the ramp-up and ramp-down of voltage to reduce settling time and optimise test speed.
- Control the ramp-up of voltage to reduce inrush current.
- Program any combination of voltage and frequency that the AC source can provide quickly and accurately. Different voltage / frequency combinations can be used within one program.

- Accurately trim to the desired output voltage to reduce errors due to the regulation of the source and the resistance of leads and connections.

Many commonly available AC sources, such as the Pacific AMX and Elgar SmartWave series, can be configured as power amplifiers.

An **AC source with remote logic on / off (only)** can also be used, but does not have the control advantages of the power amplifier configuration. The on / off control of the source must be compatible with the 5V TTL signal produced by the AC Interface.

A **step-up or step-down transformer** can be used to boost the voltage or current of the AT3600's own internal 270V 2A 40W AC source. A step-up or step-down transformer provides good control but cannot boost the power available from the AT3600. Using a good quality transformer it may be possible to provide 540V @ 1A or 135V @ 4A, for example, but only at up to 40W.

Un-controlled sources, such as the normal line supply or the output of a variable transformer (variac), can also be used with the AT3600 and the AC Interface but you will have to provide a remotely programmable switch to turn the source on and off. That switch must be controlled by the logic control of the AC Interface, as described above.

Please check the specifications of the AC Interface and your AC source before making any purchase decisions.

Summary of Advantages & Disadvantages

Source Type	Advantages	Disadvantages
AC source configured as power amplifier	<ul style="list-style-type: none"> • Simple in use; no set-up errors • Controlled turn-on for reduced inrush current • Trimmed output voltage • Flexible voltage and frequency 	<ul style="list-style-type: none"> • Cost of the source
AC source with remote on / off control only	<ul style="list-style-type: none"> • Reasonably simple in use 	<ul style="list-style-type: none"> • Cost of the source • Fixed voltage and frequency must be set-up separately • Un-controlled inrush current • Slower than amplifier
Output transformer	<ul style="list-style-type: none"> • Simple in use; no set-up errors • Controlled turn-on for reduced inrush current • Trimmed output voltage • Flexible voltage and frequency 	<ul style="list-style-type: none"> • Must be carefully selected and installed • Power limited to AT3600 generator maximum (40W)
Uncontrolled AC source	<ul style="list-style-type: none"> • Low cost 	<ul style="list-style-type: none"> • Switching circuit required • Fixed voltage and current must be set up separately • Will not do polarity tests • Uncontrolled inrush current • Slower than amplifier

1.4. OPERATING DESCRIPTION

The basic power circuit of the AC Interface provides connections on 4mm sockets for the output of the chosen source, a series current sensing device and output to the winding under test.

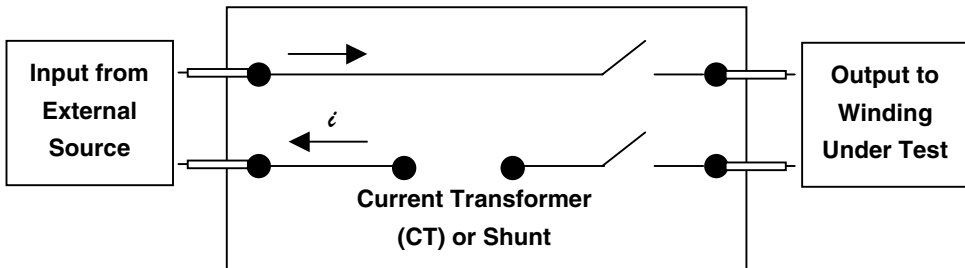

Test current flows from the external source into the fixture and out to the winding under test via an isolation relay. The current returns through the fixture via another relay and a current sensing transformer or shunt that must be fitted to the interface. A standard 1:20 current transformer is supplied with each interface.

The '**CT Input**' sockets on the fixture should be connected to the secondary of the current transformer, so that the AT3600 can measure the current in the winding under test. When a resistive shunt is used, the 'Shunt Sense' sockets provide a voltage output that is proportional to the current. These terminals must be connected to nodes 17 and 19 of the AT36600 if a resistive shunt is used.

The '**AT Transformer Drive Output**' sockets are used to drive a step-up or step-down transformer, when that type of source has been chosen.

The cable fitted to the '**AT Peripheral Port**' gland must be fitted to the peripheral port of the AT3600. This port supplies power and control signals to the AC Interface.

Control signals for an external source are available on the connector next to the gland marked '**To AC Source**'.

Full details of each function are contained in the technical information section of this manual (chapter 4).

2. INSTALLATION

2.1. GENERAL

1. Switch off the AT3600 and remove any test fixtures.
2. Read and adhere to the safety information section of this manual.
3. Fit the AC Interface Fixture to the rear of the AT3600's top platter and twist down the locking knobs.
4. Connect the lead 'To AT Peripheral Port' to the peripheral port of the AT3600 at the rear of the tester.
5. Fit the desired current transducer. Normally, you can just fit the supplied Voltech CT10-20 current transformer. For details, see the technical information section of this user manual.

2.2. POWER AMPLIFIER OR SOURCE WITH ON / OFF CONTROL

1. Switch off the power amplifier or AC source.
2. Connect the power output of the AC source to the sockets marked 'Input From External Source', using the red and black leads supplied. Observe the polarity of the connections. The source low should be connected to the black socket using the black lead.
3. Connect the control inputs of the AC source to their respective outputs from the interface via the 'To AC Source' connector. The ESE line is an enable or On / Off control; ESD is the AC control signal for the amplifier. At least one of these controls must be connected for this mode to operate without causing damage. See the technical information section of this manual for details.
4. Connect the 'External Source Output to Fixture' sockets to the test fixture using the red and black leads supplied. These are the leads that have 4mm plugs at each end.

Example Wiring: Power Amplifier or AC Source with On / Off Control

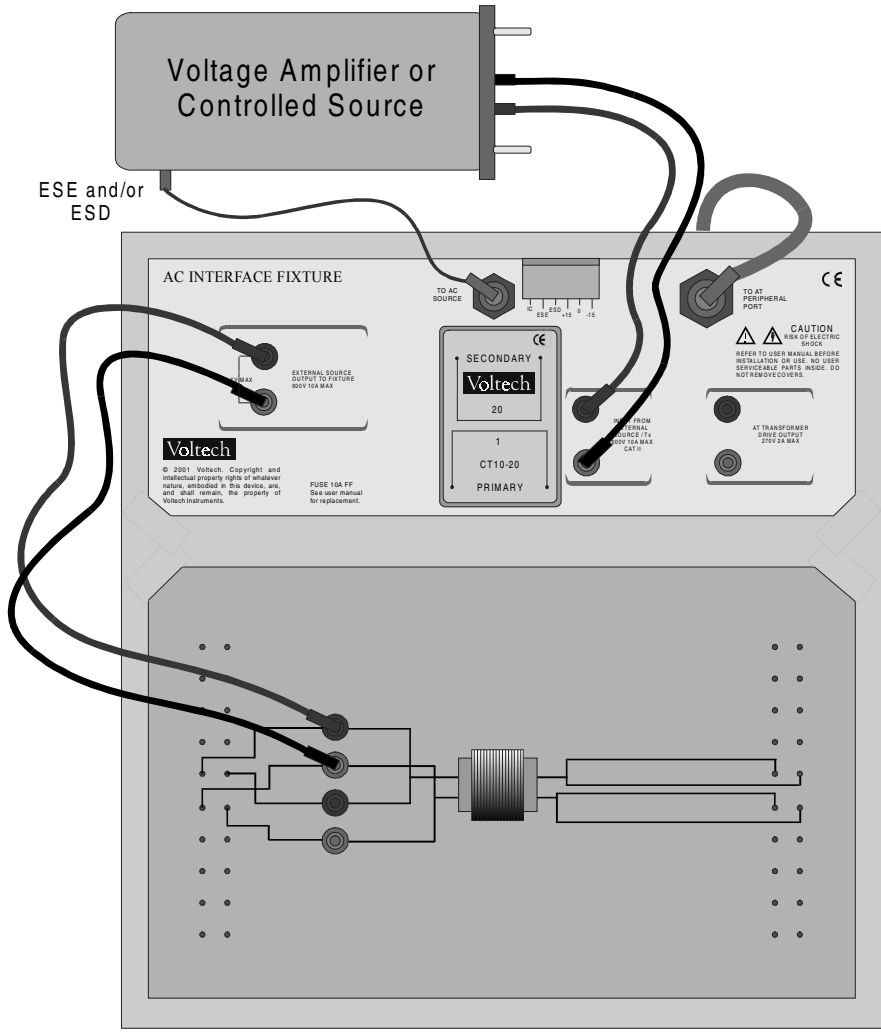

2.3. AT OUTPUT TRANSFORMER

1. Connect the primary of the transformer to the sockets marked 'AT Transformer Drive Output', using the red and black leads supplied.
2. Connect the secondary of the transformer to the sockets marked 'Input from External Source', using the red and black leads supplied.
3. Connect the 'External Source Output to Fixture' sockets to the test fixture, using the red and black leads supplied. These are the leads that have 4mm plugs at each end.

Example Wiring: AT Output Transformer

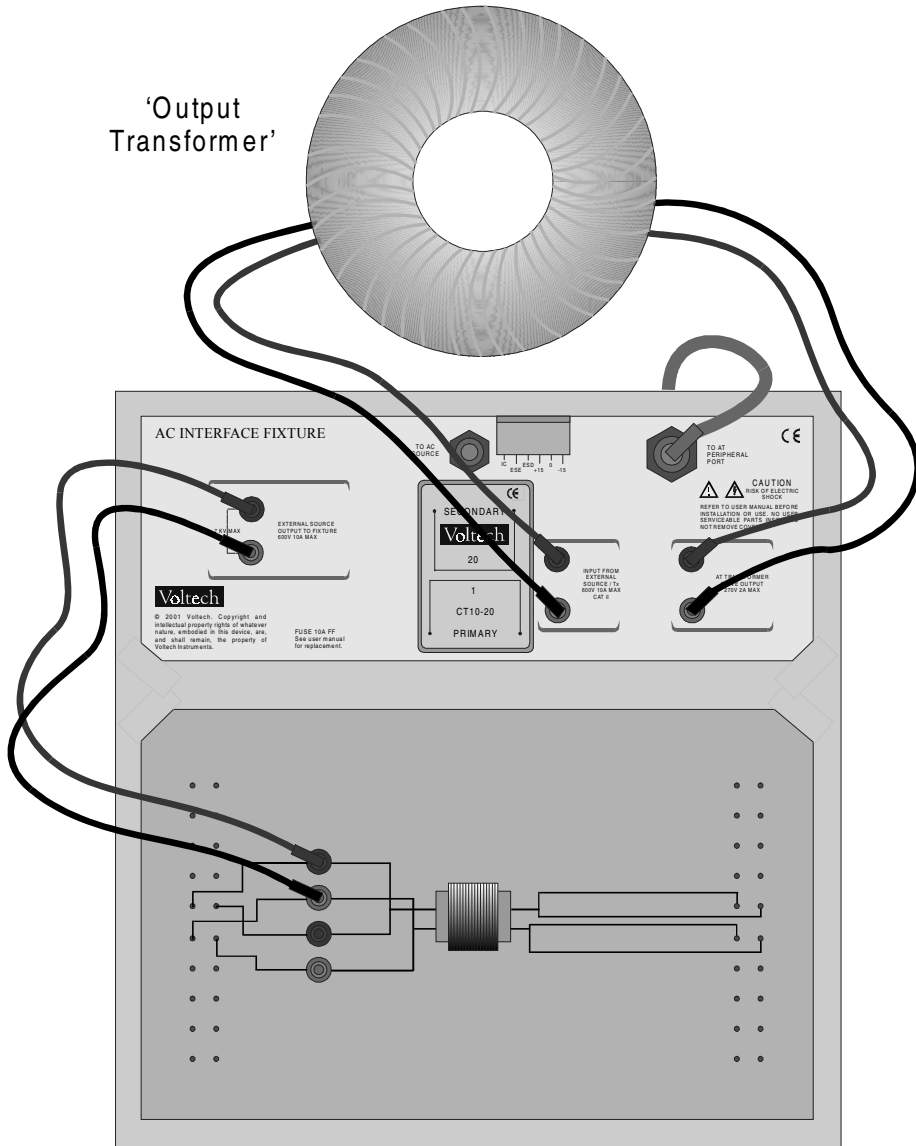

2.4. LINE SUPPLY OR MANUAL SOURCE

1. Connect the power output of the AC source to your power switch.
2. Connect the output of the power switch to the sockets marked 'Input From External Source', using the red and black leads supplied. Observe the polarity of the connections. The source low should be connected to the black socket using the black lead.
3. Connect the control input of your power switch to the ESE (External Source Enable) output from the interface via the 'To AC Source' connector. The ESE line is an enable or On / Off control. This control must be connected for this mode to operate without causing damage. See the technical information section of this manual for details.
4. Connect the 'External Source Output To Fixture' sockets to the test fixture, using the red and black leads supplied. These are the leads that have 4mm plugs at each end.

Example Wiring: Line Supply or Manual Source

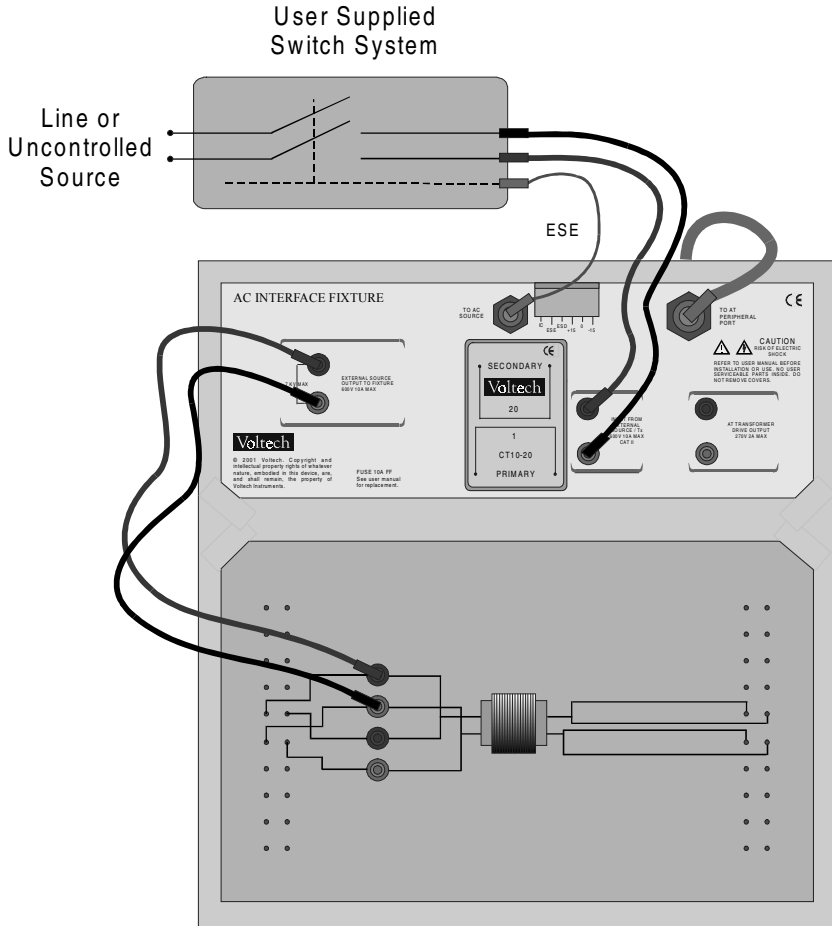

2.5. CONSTRUCTING THE TEST FIXTURE

Please refer to the 'Fixture Construction Guide' supplied with each fixture for general guidance on fixture construction.

When used with an AC Interface, the fixture requires the additional input of the test signal from 'External Source Output to Fixture' sockets of the AC Interface. These connections will provide the power for testing. **Sense connections to nodes on the fixture must also be made**, so that the AT3600 can measure and trim the voltage at the terminals of the winding under test.

In most circumstances, the power connection will also be made to the same nodes, so that the AT3600 can carry out tests that are stored in the same program but that do not use power from an external source. Once wired, the nodes must be selected for program use in the PC Editor. Note that nodes 17 and 19 must not be used if you are using a resistive shunt for current sense rather than a current transformer.

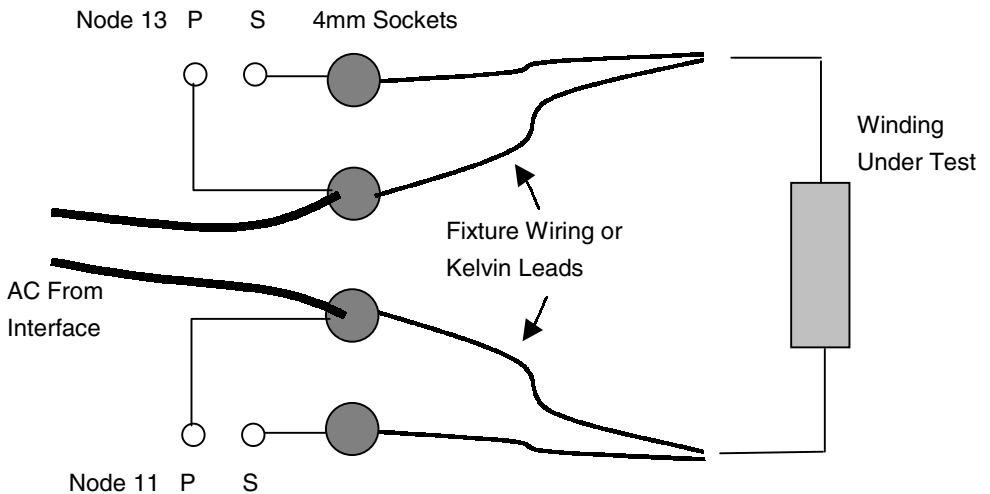

2.6. TESTING THE COMPLETE SYSTEM

To ensure that your complete test system provides operator safety and protects all components (including the AT3600) from damage, it is vital that all source control methods that you have used are working properly.

- Ensure that all connections are made as specified in this manual.
- Verify, using independent test signals, that the ON / OFF and / or amplifier input controls of your AC source or switch work properly in the expected sense.
- Test your safety interlock system.
- To avoid damage from switch-on transients, switch on the AT3600 first.
- Then switch on the AC source (if used).
- Do not fit a test part at this stage.
- Using the PC Editor, run a MAGX test at a nominal voltage. The test should complete (Pass or Fail) with no errors.
- If you see warning messages on the front panel display of the AT3600 (see the safety section of this manual), it is likely that high voltage is present. Do not touch the fixture. Follow the instructions given on the panel. The source controls are not working properly and you should investigate.
- Other errors may be reported by the Editor because the source has not switched on at all, has switched on at the wrong voltage, or the voltage sense leads are not connected.
- Check all connections, the gain settings for the source configuration in the PC Editor and that the fixture wiring is the same as that described in the Editor.
- Only after performing a successful 'no load' test should you attempt to test parts.
- If errors occur during testing, check as above but make sure that the source (including the transformer type) is capable of providing the voltage, current and frequency that you expect.

3. USING THE PC EDITOR

Once you have connected your external AC source to the AT3600 tester via the AC Interface, you will have to configure the test program in the PC Editor.

There are three steps to this configuration:

1. Configuration of the external AC source
2. Selection of the sense method
3. Selection of the external AC source in the PC Editor

3.1. CONFIGURATION OF EXTERNAL AC SOURCE

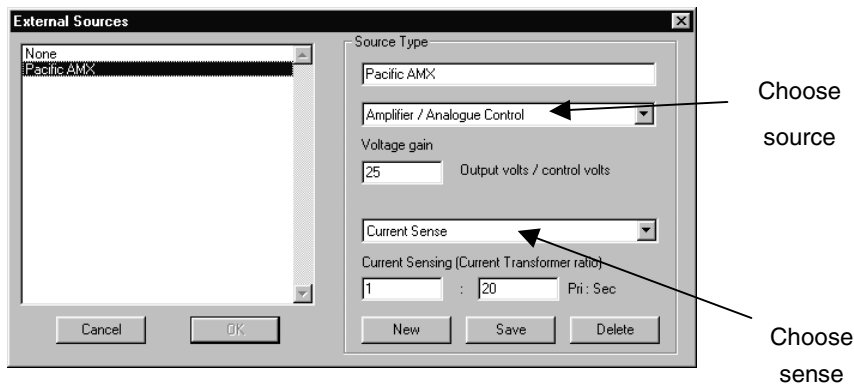

Open the PC Editor and from the 'Setup' menu choose 'External Sources'.

Click on 'New' to configure a new external source. From the 'Source Type' drop-down menu, select the appropriate source type. Then enter a name for your AC source and add the required configuration parameters. Click 'Save'. Your source now appears in the window on the left. You can modify the configuration of an existing source by highlighting its name, modifying the configuration details and clicking 'Save' again. To

delete a source, highlight its name and click on 'Delete'. Once you have configured your external AC source properly, click on 'OK' to save your set-up or choose 'Cancel' to discard any changes that you have made.

There are three types of external AC sources that you can configure for use with your AT3600 tester and the AC Interface:

- Manual Source / Line Supply
- Amplifier / Analogue Control
- AT Output Transformer

Manual Source / Line Supply

This type of source can be:

- The normal line supply straight from the wall socket (isolated or un-isolated)
- The normal line supply stepped up or down by a transformer or variable auto-transformer ('Variac')
- A synthetic AC source that is either manually set-up or pre-programmed by other equipment

IMPORTANT: This type of source must be used in conjunction with an external isolating switch or have a remote ON/OFF ability that is under the control of the AC Interface. Failure to properly connect the ON/OFF control may result in damage to your AC source, the AC Interface or the AT3600.

When configuring a manual source or line supply for use with the AT3600 and the AC Interface, you will be required to enter a trim tolerance for the source. During testing, the AT3600 will then measure the voltage applied to the part under test to ensure that the test is being carried out at the programmed test conditions. The percentage trim tolerance value is the tolerance that the tester will allow before reporting a trim error to the PC Server or Editor and failing the external source measurement.

The default trim tolerance is 10%. During program development, or when using the normal line supply, 15 or 20% trim tolerance may be appropriate. When you use a good-quality synthetic AC source, as little as 3-5% trim tolerance may be achieved.

Amplifier / Analogue Control

This type of AC source is one that can act as power amplifier. Using this type of source gives the AT3600 full control of the external source. The benefits are that:

- Different voltages and/or frequencies can be used for different tests within the same test program.
- The AT3600 will trim the output voltage during testing, so that the voltage across the test piece will always be at the programmed level, even if the gain of the source drifts or the impedances of the test parts are different.
- The AT3600 will ramp the test voltage up and down in a controlled manner, minimizing settling time and optimising test speed.

To configure this type of source, you will have to enter the nominal voltage gain of your AC source. This value is the AC output volts per AC input volts.

AT Output Transformer

This source is a transformer that may be used to boost the voltage or current that is produced by the internal high-power generator of the AT3600.

For example, a transformer with nominal 110V and 230V, 50/60Hz windings could be used to either:

- Step up the AT3600's voltage or
- Provide a higher current at lower voltages.

Using a transformer in this way cannot boost the power available. It can only provide

higher voltage at less current or higher current at reduced voltage.

To configure an AT output transformer, you will have to enter the nominal voltage or turns ratio of your source.

3.2. SELECTION OF SENSE METHOD

When setting up your external AC source for use with the AT3600 and the AC interface, you will have to choose a sense method. The AC Interface can measure current in two ways—current sense or voltage sense. You will find this configuration choice in the drop-down box below the source type configurations.

Current sense is the default method. Here, the current is measured via a current transformer, which is fitted to the AC Interface. You may enter the current transformer ratio into the dialogue box, so that the AT3600 will report the correctly scaled current. For example, the CT10-20 supplied with your AC Interface has a ratio of 1 primary turn to 20 secondary turns (1:20).

Voltage sense may also be used as a measure method. In this method, the test current is passed through a shunt resistor, and the voltage developed across the shunt is used by the AT3600 as the current measurement. (The 'Shunt Sense' terminals on the AC Interface must be connected to nodes 17 and 19 of the AT3600, in this case). For example, when you use a 0.01 Ω resistor, then 0.01 should be entered as the shunt resistance in order to achieve the correct current scaling. Note that when you measure current by the voltage sensing method, the AT3600 cannot measure power. The WATX and STRX tests are therefore unavailable.

3.3. SELECTION OF EXTERNAL AC SOURCE IN PC EDITOR

Finally, before you can use your external AC source with the PC Editor test program, you must select the source that you have configured in the Editor program options.

From the 'Program' menu, choose 'Options', and from the 'External AC Source' drop-down menu, choose the source that you want the Editor to use for external AC source tests.

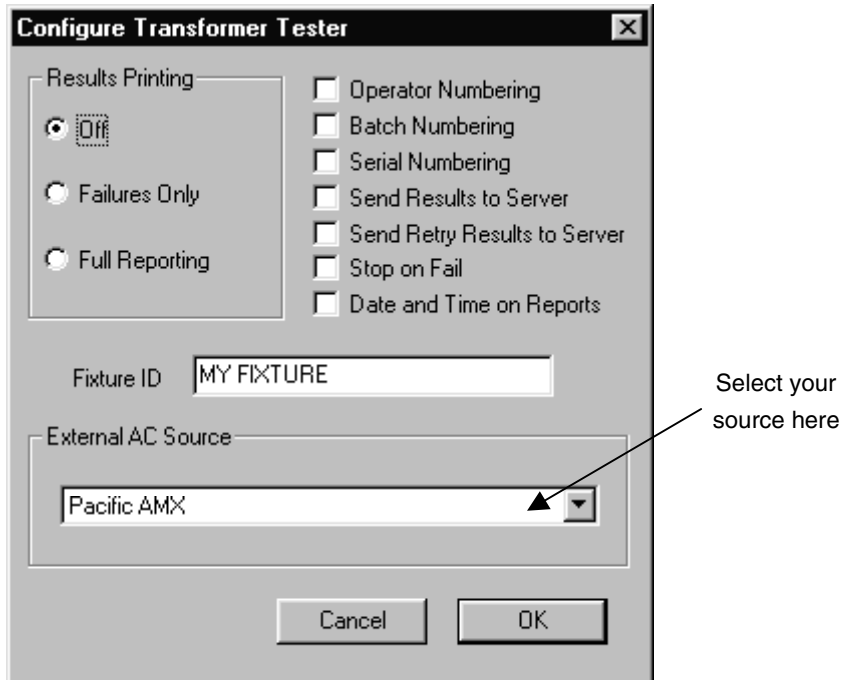

4. TECHNICAL INFORMATION

4.1. RECOMMENDED SPARES & ACCESSORIES

- Fuses:
 - SIBA FF fuse no. 70 094 40
 - 10A RMS rated
 - 600V RMS rated
 - Size 38.1mm long x 10.3mm wide
 - RS part no. 209-9406
- True Kelvin leads, 2A rated (Voltech part no. 78-028)
- Flying lead connection post (Voltech part no. 78-026)
- Universal lead set (Voltech part no. 78-030), contains 10 of each of:
 - True Kelvin leads (78-028)
 - Flying lead connection post
 - Non-Kelvin croc-clip leads
 - Grabber clip leads
- Universal fixture plate (20-node connection plate, Voltech part no. 91-186)
- True Kelvin leads, 10A rated (Voltech part no. 78-060)
- Twin core cable 270V AC RMS, 3A rated or equivalent for output uses of the high-power amplifier from the AC Interface Fixture (Farnell part no. 721-281)
- Sub-miniature screened 7/0.1 multi-core with minimum of seven cores for all other connections to the 6-way connection block of the AC Interface, labelled 'To AC Source' (Farnell part no. 711-380)

4.2. DETAILS OF CONNECTOR FUNCTIONS

'EXTERNAL SOURCE OUTPUT TO FIXTURE'

These connections are used to supply the signal from the AC Interface to the part under test. Note that when the AT3600 runs a hi-pot test as part of a test program, up to 7kV could be present on these connections.

It is therefore very important that the leads used to make connections here are not accessible to the user without having to break the safety interlock (e.g. through a light curtain), because the Voltech supplied leads for this position are not touch-proof to 7KV.

'INPUT FROM EXTERNAL SOURCE'

These connectors are used as the input from the external source or step-up transformer to the AC Interface. It is a CAT-II interface, capable of carrying 600V RMS, 850Vpk and 10A RMS, 35Apk. It is important to observe the polarity of the signal connected here to ensure that the common-mode voltage applied to the CT primary or shunt connections is at a minimum. This will give maximum accuracy for current measurements.

'AT TRANSFORMER DRIVE OUTPUT'

These connections are intended to drive a user-supplied transformer for use as the external source. They supply an output of up to 270V RMS, 2A RMS (3Apk) and a 40W maximum, which is derived from the internal high power amplifier of the AT3600. For convenience, this connection can also be made straight through the 'Input from External Source', without a transformer, to perform the same high-power tests the AT is normally capable of. The maximum frequency available using this connection is 1.5kHz. It is important to observe the polarity of the signal connected here to ensure that the common-mode voltage applied to the CT primary or shunt connections is at a minimum. This will give maximum accuracy for current measurements.

'To AC SOURCE'

This port carries six possible connections that can be made by inserting wire and screwing down connections.

Terminal block:

Max. wire capability:	2.5mm ² , fine stranded
	4mm ² , solid
	14-12 AWG
Clamping screw torque:	0.5Nm

Cable gland:

Min. cable diameter:	4mm
Max. cable diameter:	8mm

A suitable cable to use for both connectors would be a multi-core to DEF STAN 61-12 part 5-unscreened 16/0.2 type 16-2-6A, which consists of six cores of 2.5A 440V RMS rated wire in an overall sheath of 7.3mm (EG Farnell part no. 715-608).

The following pin-outs cover controlled AC source operating modes, using the 6-way output connector. This connector is comprised of six active pins:

ESE (External Source Enable Pin 2)

This connection is used for controlling an external source that has an enable or power-on input. It can also be used for controlling a user-supplied switch that activates power from an uncontrolled source such as the normal line supply or a variac. The output is 5V TTL compatible. It is short circuit-protected. A high on this line means the power should be applied to the AC Interface Fixture.

ESD (External Source Drive Pin 3)

This connection is used to provide the analogue control signal for an analogue

controlled source or amplifier. The test program that is being run in the AT controls the amplitude and frequency of this signal. When a test program is being executed, the AT will set this signal to be a sinusoid at the specified frequency between 20Hz and 1MHz.

The signal is of 0 to 5 V AC. The input impedance of the amplifier should be greater than 600 Ohms.

IC (Isolator Control Pin 1)

Normally, the output voltage and current of an AC source or power amplifier are fed through the AC Interface. The Interface contains high-voltage relays that isolate the source from the AT3600 when tests that do not use the external source are being performed. This allows the AT3600 to perform small-signal tests like inductance, LS, without being loaded by the output impedance of the source, and to protect the source from damage when the AT3600 is performing high-voltage tests like hi-pot, HPAC.

It is normally not necessary to use an external isolator, and users are strongly urged to contact Voltech before doing so. If you do wish to use an external isolating device, then this signal may be used to control that device. This output is 5V TTL compatible and short circuit-protected. The external isolation switch must be closed when this line is 'high'.

Control Timing

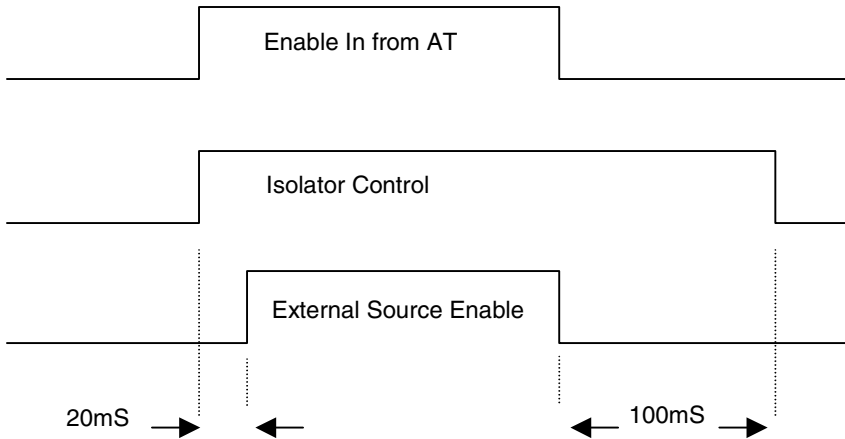

The diagram above shows the signal levels (high or low) and the times between them from when the AT3600 asserts its enable signal. The Enable In (from AT) is not visible on any ACIF ports. It is a control line that comes in from the AT3600 peripheral port.

When the AT initiates an external source test, it asserts Enable In and leaves this signal high until the end of the test. Within a few microseconds of 'Enable In', the Isolator Control line is also asserted. This line can therefore be used to control an external isolating switch like the relays in the AC Interface itself. In fact, this signal is used internally to switch these relays.

20mS after the 'Enable In' and 'Isolator Control' lines are activated, the 'External Source Enable' signal is activated. The ESE line must be used to go to a control port on an external source or to switch a device that applies power from an external source, where control is not possible. The 20mS delay ensures that the AC Interface relays or other external device connected to the Isolator Control signal have switched completely before an external source is activated, which ensures that the isolator does not switch the current on to the load.

As soon as Enable In goes low, the ESE signal is switched to low within microseconds, turning the external source off as quickly as possible. The Isolator Control line remains high for another 100mS to allow time for the source to switch off and any transients to decay.

+15V (Pin 4), -15V (Pin 6)

This is a +15V and -15V supply. See note below for full specification.

0V (Pin 5)

This is the 0V reference for all other connections on the source control port.

Note:

The +/-15V supply is intended for use with a current sensing module, e.g. a LEM module, which requires power to deliver current to the measurement device.

Voltage set accuracy	± 3%
Regulation	- Load variation 10 - 100% - Balanced load ± 1.0% max. - Unbalanced load ± 3.0% max.
Ripple and noise (20MHz bandwidth)	50mVpk-pk max.
Temperature coefficient	± 0.02% / °C
Output current limitation	> 120% Iout max., constant current
Short circuit protection	- indefinite
Capacitive load	- 470µF max.
Maximum current (Iout max)	35mA

Please note that this supply is also used internally by the AC Interface Fixture, and that the system will not function if the + or – supply is used incorrectly, although no damage will occur.

'To AT Peripheral Port' (Fixed Cable)

This part of the fixture will have a factory-fitted cable. It is not intended to be replaced by the end-user. This cable has a 15-way D connector on the end that must be plugged into the AT3600 peripheral port. All signals to and from the AT3600, including the power supply for the AC Interface Fixture's internal circuitry, are sent down this cable.

'CT or Shunt'

These connections are used for fitting the primary of a CT or shunt resistor in series with the power path. Without a CT or shunt fitted here, no low connection will be made to the output of the fixture. These connections will carry the same voltages and currents as the external source input.

'Shunt Sense'

These connections are wired directly in parallel with the 'CT or Shunt' connections to provide a Kelvin (or 4-wire) connection to a shunt. These connections are used to carry the sense voltage from the shunt resistor fitted to nodes 17 and 19 of the AT switching matrix.

'CT Input'

The AT3600 can measure the current that is applied to these terminals. The secondary of any current transformer that has its primary connected to the 'CT OR SHUNT' terminal should be connected here. The maximum value is 1A RMS, 3.5Apk. The AT3600 measures this current and multiplies the result by the CT ratio (i.e. 20 for the Voltech CT10-20) to obtain the final current value.

4.3. USING A CURRENT TRANSFORMER

The Voltech CT10-20 Current Transformer

The CT10-20 is a current transformer module that is supplied with the Voltech AC Interface Fixture to enable current measurements to be made with the AT3600. The name is derived from its basic specification of 10Arms and a ratio of 1:20.

The CT10-20 is designed to plug directly onto the AC Interface Fixture as a module. It cannot be incorrectly fitted. Using the CT10-20 is the manufacturer's preferred method.

Specification

Turns ratio:	1:20
Frequency response:	20Hz to 20kHz
Magnitude accuracy:	Better than 2% (20Hz – 20kHz) Better than 1% (45Hz – 5kHz)
Phase accuracy:	Better than 3 degrees (20Hz – 20kHz) Better than 1 degree (45Hz – 5kHz)
Maximum current:	10Arms (15A _{pk})
Isolation:	4KV primary to secondary

The above specification is valid when the CT10-20 is fitted to an AC Interface Fixture that is connected to an AT3600. The specification may vary with different burden impedances (the impedance connected across the secondary).

Selecting Other Current Transformers

A CT (current transformer) is a transformer designed not to accurately transform voltage levels between windings, as most transformers, but to transform currents. CTs are designed to present a very small series impedance on the primary winding, so the current flow in the main signal path is disturbed as little as possible. A CT has a proportion of the primary current flowing in the secondary that is defined by the CT turns ratio. The Voltech CT10-20 has a ratio of 1:20, so whatever current flows in the primary, 1/20 of that current must flow in the secondary.

When designing a CT, there are a number of important parameters that must be taken into consideration. Some of these are as follows:

1. The minimum and maximum currents to be measured.
2. The required accuracy of the measurements.
3. The burden resistance (resistance on the secondary) of the measurement device.

When choosing a CT for operation on the AC Interface Fixture, the first important parameter to make note of is the minimum current that the AT3600 can measure accurately and the burden resistance that is presented to the system. The AT3600 can accurately measure about 1/20mA (to about 1%). As currents get smaller than this, noise in the system and other effects due to large currents flowing in the AC Interface start to swamp the true signal that is being measured. The burden resistance in the AT3600 changes depending on the level of the current being measured, because the internal shunt is changed automatically depending on the signal level.

1. Between 0 and 12mA peak, the burden is 12 Ohms.
2. Greater currents than this result in a burden of 2.5 Ohms.

This burden resistance is reflected back to the primary of the CT by the square of the turns ratio.

$$Z_p = Z_s \times N_p^2 / N_s^2$$

Therefore, for the Voltech CT10-20, the primary impedance $Z_p = 12 \times 1^2 / 20^2 = 0.03$ Ohms (for a 12 Ohm burden) and $Z_p = 2.5 \times 1^2 / 20^2 = 0.00625$ Ohms for a 2.5 Ohm burden. This ensures that the effect on the main current measurement is very small.

4.4. HOW TO CHOOSE A SHUNT

A current transformer is the preferred method of measuring current, since it allows the AT3600 to calculate power as well as current and does not require extra connections from the AC Interface to the test fixture. Measurement of power is not possible when a shunt is used.

A shunt resistor must be fitted between the 'CT OR SHUNT' terminals on the AC Interface. A Kelvin connection to the 'CT OR SHUNT' terminals is provided via the 'SHUNT SENSE' terminals. These terminals must be connected to the 'sense' of nodes 17 and 19.

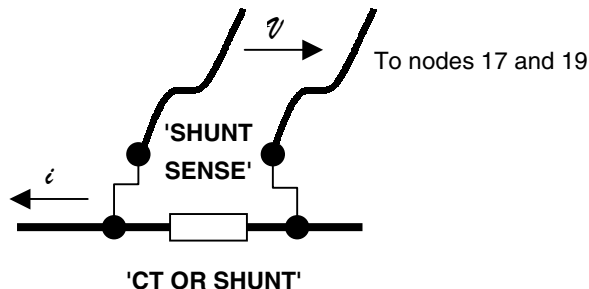

If you are using a transducer that produces a voltage that is proportional to the current being measured, then the input of the transducer must be connected across the 'CT OR SHUNT' terminals and its output must be connected to nodes 17 and 19.

A shunt resistor is normally a very stable and accurate resistance inserted in series with the signal path. The current that flows through the part under test also flows through the resistor and generates a voltage across it. This voltage is then measured, and the current flowing is derived using the formula $I = V/R$, where I is the current flowing, V is the voltage measured across the shunt resistor, and R is the resistance of the shunt resistor.

When a shunt resistor is fitted to the AC Interface Fixture, some sense connections are available that must be connected to the measure nodes of 17 and 19 on the AT3600 top platter. The AT3600 will expect to measure the sense voltage on these nodes, when an external source configured to use a shunt is being used. The value of the shunt resistance must be configured within the PC Editor software. The value is directly entered in Ohms. When a source is configured in this way, the Editor software will not allow any transformer windings to be connected to nodes 17 and 19.

Please allow for the following parameters when selecting a suitable shunt resistor:

1. Ensure the resistance value is low enough not to interfere with the measurement being made. As a guide, try and ensure that the voltage generated across the resistor, when maximum current flows, is less than 1% of the test voltage.
2. Ensure that the power dissipation is high enough. A resistor dissipates I^2R Watts when a current I flows through it.
3. Pick a stable resistor type that does not vary significantly with temperature. If it varies, the results returned by the AT3600 will vary accordingly.

You should also pick a resistance value that produces a significant voltage across it, so the AT3600 can measure it accurately. As a general rule, keep the sense voltage to at least 10mV RMS at the minimum current expected through the part under test. There is no practical upper limit to the sense voltage. It can be up to 850Vpk.

4.5. CHOOSING AN AT OUTPUT TRANSFORMER

A step-up or step-down transformer can be used as an AC source in conjunction with the AC Interface. The transformer can be used to either increase the voltage or the current available from the AT3600's own internal generator. This is an extremely versatile method to use for testing transformers, providing good control and optimum test speed. A transformer cannot however boost the power available from the internal generator of the AT3600, which is 40W.

The transformer that you choose to use should:

- Have low losses to maximise the power available.
- Have a turns ratio with sufficient margin to absorb any voltage regulation. (Remember that the AT3600 will attempt to trim to the desired test voltage during test).
- Have sufficient VA rating to carry the current to the winding under test.
- Be designed to operate at the range of voltage and frequency conditions that you will be using it at. If, for example the AT3600 applies 230V, 50 Hz to a winding designed to operate at only 110V, 60Hz, the transformer is very likely to saturate. The test will fail with errors.
- Preferably be housed in a safety enclosure to provide the best operator safety.
- Have all interconnecting leads inside the zone protected by your AT3600 safety system.

5. SPECIFICATION

5.1. TESTS AVAILABLE FOR USE WITH THE AC INTERFACE

The following tests are available for use with an external AC source, when a Voltech AC Interface is used in combination with an AT3600:

Test		User Entered Test Data			$A_R^{(3)}$
		Measurement Range	Test Signal	Test Frequency ^{(1) (2)}	
MAGX	Magnetizing Current	10 μ A to 10kA	5V to 600V	20Hz to 20kHz	0.1%
VOCX	Open Circuit Voltage	100 μ V to 650V ⁽⁴⁾	5V to 600V	20Hz to 20kHz	0.1%
WATX	Wattage	1mW to 10kW	5V to 600V	20Hz to 20kHz	1%
STRX	Stress Wattage	1mW to 10kW	5V to 600V	20Hz to 20kHz	1%

Notes:

- 1) Specification using supplied CT10-20. Up to 1MHz possible with suitable current transducer.
- 2) 1.5kHz when using the AT3600's internal source to power output transformer source type.
- 3) A_R = basic relative accuracy
- 4) 650Vrms for AC measurements, or 900V for DC measurements.
- 5) Specification valid at 23 ± 5 °C.

5.2. MAGX – MAGNETISING CURRENT

The accuracy for measuring magnetising current, using an external AC source is:

$$A_T = A_R + A_C + A_I + A_S + A_{SRCE}$$

Where:

A_T is the total accuracy (%).

A_R is the basic relative accuracy (%).

A_C is the calibration accuracy (%).

A_I is the correction for the current level (%).

A_S is the error in the current measurement from the sensing system (%).

A_{SRCE} is the correction for the external source type (%).

The value of A_R is given in the table above.

$$A_C = 0.03\% + (0.001 \times F_M)$$

A_S = derived from CT or shunt accuracy

A_{SRCE} = 3.0% for manual / line and analogue supply

= 0.0% for AT output transformer

F_M is the test frequency (Hz).

I_M is the measured current (A).

V_M is the measured sense voltage (V).

When using a CT:

$$A_I = 0.03\% + (0.0001 / I_M) + (2 \times I_M)$$

When using a shunt:

$$A_I = 0.03\% + (0.001 / V_M)$$

During a MAGX test, the AT3600 automatically applies the test voltage to the part under test and checks that the voltage has stabilised before recording measurements. The time that the voltage takes to stabilise will vary with the source type used and the nature of the part under test.

5.3. VOCX – OPEN CIRCUIT VOLTAGE

The accuracy for measuring open circuit voltage is given as:

$$A_T = A_R + A_C + A_V + A_{SRCE}$$

Where:

- A_T is the total accuracy (%).
- A_R is the basic relative accuracy (%).
- A_C is the calibration accuracy (%).
- A_V is the correction for voltage level (%).
- A_{SRCE} is the correction for the external source type (%).

The value of A_R is given in the table above.

The values of the other factors are given below.

- $A_C = 0.03\% + (0.001\% \times F_M)$
- $A_V = 0.03\% + (0.001\% / V_M)$
- $A_{SRCE} = 0.5\%$ for manual / line supply
 $= 0.0\%$ for analogue / amplifier and AT output transformer

Where:

- F_M is the measurement frequency (Hz).
- V_M is the measured voltage (V).

During a VOCX test, the AT3600 automatically applies the test voltage to the part under test and checks that the voltage has stabilised before recording measurements. The time that the voltage takes to stabilise will vary with the source type used and the nature of the part under test.

In general (and especially for programmable and AT output transformer source types), the AT3600 will record a measurement very quickly (typically in less than 0.5 seconds), which is desirable in a production test environment.

If the measurement were to be recorded after a longer period of time under power, slightly different readings may be obtained due to self-heating effects in the part under test. This effect may be noticed when comparing results taken using different source types or slower measurement systems.

5.4. STRX & WATX – STRESS WATTAGE & WATTAGE

The accuracy for the measurement is given by:

$$A_T = A_{MAGX} + A_{VOCX} + A_P + A_\theta$$

Where:

A_T is the total accuracy (%).

A_{MAGX} is the accuracy for the current measurement (see MAGX specification) (%).

A_{VOCX} is the accuracy for the voltage measurement (see VOCX specification) (%).

A_θ is the correction for current sense phase error (%)
and

$$A_\theta = \text{Tan}(\text{Cos}^{-1}(\text{PF})) * \theta_s$$

A_P is the correction for power factor (%)

and

$$A_P = (1 + 0.0007 * F_M) * (\sqrt{1 - PF^2} / PF)$$

Where:

PF is the power factor of the load ($PF = W / VA$).

θ_s is the phase error in the current sense device (degrees Radians).

F_M is the measurement frequency (Hz).

When performing either of the above tests, the AT3600 automatically applies the test voltage to the part under test and checks that the voltage has stabilised before recording measurements. The time that the voltage takes to stabilise will vary with the source type used and the nature of the part under test.

In general (and especially for programmable and AT output transformer source types), the AT3600 will record a measurement very quickly (typically in less than 0.5 seconds), which is desirable in a production test environment.

If the measurement were to be recorded after a longer period of time under power, slightly different readings may be obtained due to self-heating effects in the part under test. This effect may be noticed when comparing results taken using different source types or slower measurement systems.

5.5. TYPICAL EXTERNAL AC SOURCE SPECIFICATION

Raw isolated or un-isolated line power. Up to 600Vrms.

AC power amplifier:

0-5Vac input at rear. Input impedance $>600\Omega$.

Voltage gain:

x 100 typically. Selectable in the Editor.

Current:

Up to 10Arms, 30 A 'continuous' peak (e.g., crest factor of 3 at 10Arms).

Voltage:

5V minimum, 600Vac rms maximum.

Frequency range:

20Hz to 1MHz.

AT output transformer:

Frequency range:

20Hz to 1.5KHz.

5.6. GENERAL

Size:	290mm x 110mm x 32mm
Weight:	Approx. 750g
Power supply:	Powered by the AT3600
Operating temperature:	0 to 40°C
Storage temperature:	-40 to 70°C
Humidity:	10 to 90% RH, non-condensing

5.7. EMC COMPLIANCE

DECLARATION OF CONFORMITY

Manufacturer's name: **Voltech Instruments Ltd**
Manufacturer's address: **65 Milton Park**
Abingdon
Oxfordshire
OX14 4RX UK

Declares that the product: '**AC Interface**' conforms with the following product specifications, when used with a Voltech AT3600 Transformer Tester:

Safety: BS EN 61010 (1993)
BS EN 954 (Category 3)
BS EN 60204

EMC: BS EN 55022 (1995): Class A
BS EN 50082-2 (1992)

The 'AC Interface' herewith complies with the requirements of the EMC Directives 89/336/EEC and 92/31/EEC and the Low Voltage Directive 73/23/EEC.

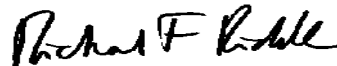

Signed on behalf of Voltech Instruments Ltd.

Richard Riddle,
Quality Manager

Abingdon, U.K., September 13, 2001

5.8. EMC PRECAUTIONS

Conducted and Radiated Emissions

The AC Interface Fixture complies with the limits of BS EN 55022 Class (A), when used in conjunction with an AT3600 transformer tester.

Immunity

The AT3600 and AC Interface Fixture may be susceptible to fast electrical transients on the power line and electrostatic discharges, which may disrupt the operation of the unit.

In the event of such an occurrence, to return the system to normal operation:

Switch off the power to the AT3600.

Wait 5 seconds.

Switch the tester on again.

6. WARRANTY & SERVICE

6.1. WARRANTY

The Voltech AC Interface Fixture is warranted against defects in materials and workmanship for a period of twelve (12) months from the date of shipment.

In the event of failure of a customer unit during this period, Voltech will:

- At Voltech's discretion, repair or replace the faulty unit free-of-charge for a unit returned to an authorized service centre. Shipment from the customer address will be the responsibility of the customer.

Voltech reserves the right to waive this benefit in any event where it is clear upon inspection that the cause of the failure is due to customer misuse.

Voltech will be the sole arbiter in this circumstance.

- Pay all return shipment charges from the Voltech service centre to the customer.
- Repair/verify the customer unit before dispatch. A certificate of verification will be issued as a matter of course.

Because software is inherently complex and may not be completely free of errors, you are advised to verify your work. In no event will Voltech be liable for direct, indirect, special, incidental or consequential damages arising out of the use of or inability to use software or documentation, even if advised of the possibility of such damage. In particular, Voltech is not responsible for any lost profits or revenue, loss of use of software, loss of data, cost of substitute software, claims by third parties, or for other similar costs. In no case shall Voltech's liability exceed the amount of the license fee.

6.2. SERVICE

To confirm the accuracy of your AC interface fixture, a verification check should be carried out every 12 months.

Verification is carried out using purpose-built equipment. The verification can be performed by an authorised Voltech service centre.

For details of verification facilities and any other service requests, contact your supplier. Voltech strongly recommends that you discuss your service requirements with your supplier before service is needed.

6.3. OBTAINING SERVICE AND APPLICATIONS SUPPORT

Voltech personnel will be happy to help you with any query that you may have. Please e-mail your local supplier or your regional Voltech service centre, as listed at the front of this manual.

To ensure we provide the fastest possible support, we may ask you for:

- The serial number of your AC Interface Fixture (found on the back of the fixture)
- The firmware revision level of the AT3600 that you are using (shown on the AT3600's front panel during power-on)
- The software revision levels of the PC Editor and Server software that you are using.

7. SAFETY INFORMATION

7.1. SAFETY FEATURES

The AC Interface has been designed with several fault-tolerant safety features that provide the operator with a high level of protection against the risk of electric shock. As with any dangerous equipment, however, it is important that an assessment of the overall risk to safety is made during installation. It is the user's responsibility to ensure compliance with any regulations that may be applicable to the health and safety of operators.

7.2. SAFETY INSTRUCTIONS

**WARNING:**

Voltech's AC Interface Fixture can pass voltages of up to 600VRMS and 10ARMS during testing. It is essential that an approved safety interlock system, such as the Voltech light curtain, is installed and maintained in accordance with the guidelines given in the AT3600 user manual.

- Do not coil any of the high-voltage connection leads.
- Replace the fuse only with the same type and rating as specified in this manual.
- Refer servicing only to qualified personnel who understand the danger of shock hazards.
- Ensure operators are aware of the potential shock hazard.
- Ensure operators are trained to avoid making contact with the part being tested or any exposed parts of the fixture during testing.
- Beware of energy stored with the capacitance or inductance of the part being tested when handling the part after test.

- Whenever possible use the external source enable line to switch off the external source when not in use.
- Ensure that all equipment used is earthed.
- Ensure that cables are secure.

Maintenance

- Test the safety interlock system weekly.
- Examine all test leads for damage to insulation by overheating weekly and replace if required.
- Return the AC Interface and all leads to Voltech annually for a safety and performance verification.

7.3. ERROR MESSAGES

There are two error messages relating to faults within the Voltech AC Interface Fixture:

- Internal fault condition:
Safety interlock open (also shows “Safety Interlock Open” message on the AT3600 display). The error message displayed in the PC Editor is shown below.

A fault has occurred with the external source. Please check the status of the external source interface and refer to user manual.

Should this error occur, check the operation and installation of the safety light curtain (see AT3600 user manual).

- When the AT3600 detects a voltage level $>40V$ preceding a test, the error message shown below is displayed on the AT3600's front panel.

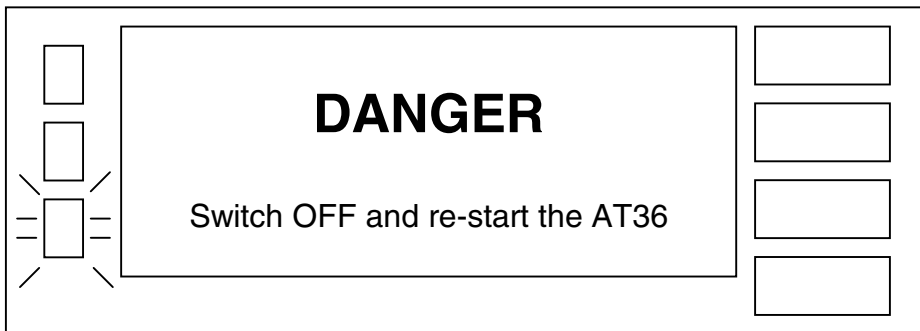

- Should this occur:
 - **DO NOT TOUCH THE PART UNDER TEST OR THE FIXTURE.**
 - Switch off the AC source.
 - Switch off the AT3600.
 - Check to make sure the part under test is safe to touch before removing it and powering on the AT3600 and AC source.

7.4. COMPLIANCE WITH EN954

The AC Interface meets the requirements of category 3 of EN954 (safety-related parts for control systems), and as such will protect against most faults associated with high-voltage AC sources. Should any single part fail in the AC Interface Fixture, there will be no loss of the safety system function. Of the three test modes, maximum protection is afforded to the high-power generator (used for the step-up or step-down transformer test mode), where the system will meet category 4 of EN954.

EN954 Category 4

This category defines that any single fault occurring within the safety system will not cause loss of the safety function, and any single fault will be detected before a second fault could occur creating a loss in the safety function.

The AC Interface Fixture will comply with a category 4 system when using an output transformer that is energised by a source within the AT3600 along with a Voltech approved safety system, because the Voltech safety system guarantees that the connection to the output transformer is disconnected, when the interlock is broken.

EN954 Category 3

This category defines that any single fault occurring within the safety system will not cause loss of the safety function and recommends that, when possible, any single fault will be detected before a second fault could occur creating a loss in the safety function, although this is not mandatory. As an extra precaution in this case, if the system is rendered unsafe, there must be a high probability that the user can avoid the hazard.

The Voltech AC Interface will always meet category 3, if connected correctly to an external AC source, as described in this manual. The AC Interface Fixture has been designed so that any single fault will not render the system unsafe and, if multiple faults occur, a clear indication will be given to the user if dangerous voltages are present after testing a wound component.

Voltech

www.voltech.com

AC Interface

Voltech Instruments Ltd.

65 Milton Park
Abingdon, Oxfordshire
OX14 4RX
U.K.

Tel: +44 1235 834555
Fax: +44 1235 835016

sales@voltech.co.uk

Voltech Instruments Inc.

2725 East Millbrook Road
Suite 121
Raleigh, NC 27604
U.S.A.

Tel: +1 919 431 0015
Fax: +1 919 431 0090

sales@voltech.com